

STRAIGHT SLIDING 290 HENDERSON

150kg 200kg Wood Metal Exterior

For sliding wooden and metal doors weighing up to 150kg and 200kg

Overview

Catering for wooden and metal doors, our Straight Sliding 290 allows for the easy movement of anything from light commercial doors up to very heavy and large industrial applications. With a range of components to choose from, Straight Sliding 290 can be specified to meet your exact requirements.

Features and Benefits

- Can cover any width of opening, any number of doors can be used on single or multiple lines of track
- Designed to accommodate for different building designs, doors can slide to one or both sides
- Wicket door for easy access may be incorporated into a sliding door



Product and Door Specification

Product	Door Thickness Range	Max. Door Weight
Straight Sliding 290	35 - 48mm	150kg or 200kg

Component Specification

Component	Description	Short Code	
		150kg	200kg
Track (Twice the width of doors)	Galvanised steel track in 2000, 2500, 3000, 4000, 5000 and 6000mm lengths	290/**** (2mm thick)	
Steel Brackets (900mm max spacing and at track joints) ** RC for right hand closing and LC for left hand closing	Face fixed - single	1/290S	
	Face fixed - single - jointing	1X/290S	
	Face fixed - single - low headroom	9/290S	
	Face fixed - single - low headroom jointing	9X/290S	
	Face fixed - single - closed end bracket	1/290S**	
	Soffit fixed - single - adjustable	4R/290S	
	Soffit fixed - single - adjustable jointing	4RX/290S	
	Soffit fixed bracket body (for welding)	4R/290SB	
Aluminium Brackets 900mm max spacing and a track joint	Face fixed - single	1A/290	
	Face fixed - single - jointing	1AX/290	
	Face fixed - double	5/290	
	Soffit fixed - single	3A/290	
	Soffit fixed - single - jointing	3AX/290	
	Soffit fixed - single - 'in line'	4A/290	
	Soffit fixed - single - 'in line' jointing	4AX/290	
Bracket Endclips	End clip to close open brackets	1A/290EC	
Hanger (2 per door) */S = steel wheel */N = nylon wheel	Metal door - 2 wheel - standard bolt	56.5K/*	
	Metal door - 4 wheel - standard bolt	56K/*	56K/*200
	Metal door - extended bolt	56KX/*	
	Wood door - 4 wheel - side plate	53K/*	53K/S200
	Wood door - 4 wheel - top plate	57K/*	57K/S200
	Wood door - 4 wheel - angle plate	52K/*	52K/S200
	Curtain sided vehicle - 4 wheel	56MVS	
Guide Channel* Same length as track	Galvanised steel channel in 2000, 2500, 3000, 4000 and 6000mm lengths	89/****	
	Brass channel in 1500mm and 3000mm lengths	94/****	
	Aluminium channel in 1500, 2000, 2500, 3000 and 4000mm lengths	94X/****	
	Bottom rail in 2000, 2500 and 3000mm lengths	299/****	
	Fixing lug	97LUG	
	Channel couplers	UNICUP	

Component Specification - continued

Component	Description	Short Code	
		150kg	200kg
Guides	Metal door	104P/89	
	Metal door - extended	104PX/89	
	Wood door - side fixed	105R/89	
	Wood door - concealed	106R/94	
	Wood door - end fixed	113R/94	
	Metal or wood door - stop guide	112	
	Metal or wood door - ground stay roller	126	
	Metal or wood door - heavy duty ground stay roller (assembled)	126HD/A	
	Metal or wood door - shoe guide	128	
	Metal or wood door - wall mounted, for single doors	31S	
Metal or wood door - wall mounted, for double doors	31D		

**** Replace with required length for full short code

*All channels supplied with lugs and couplers included except 94 and 94X

For Wooden Doors

For Metal Doors

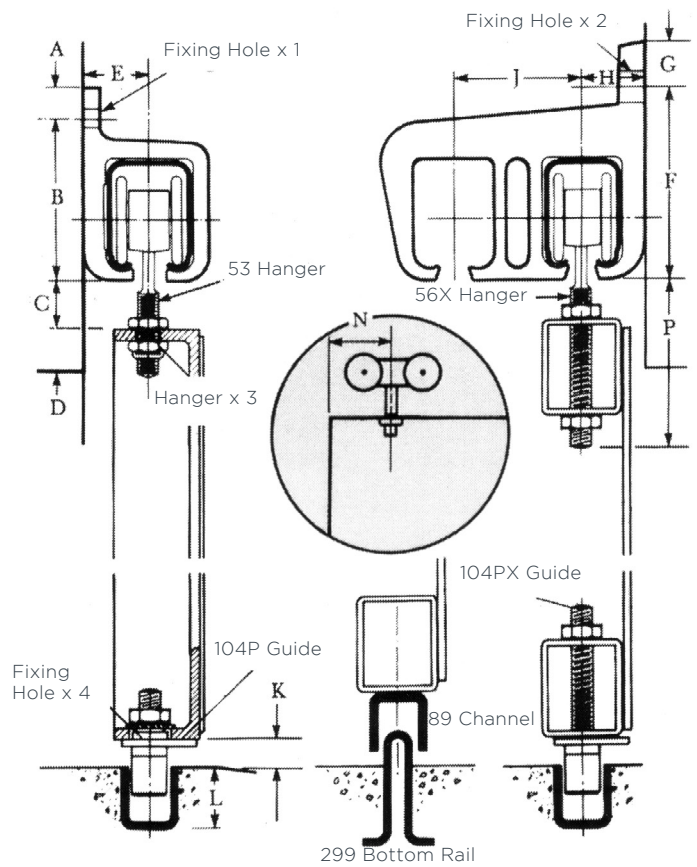
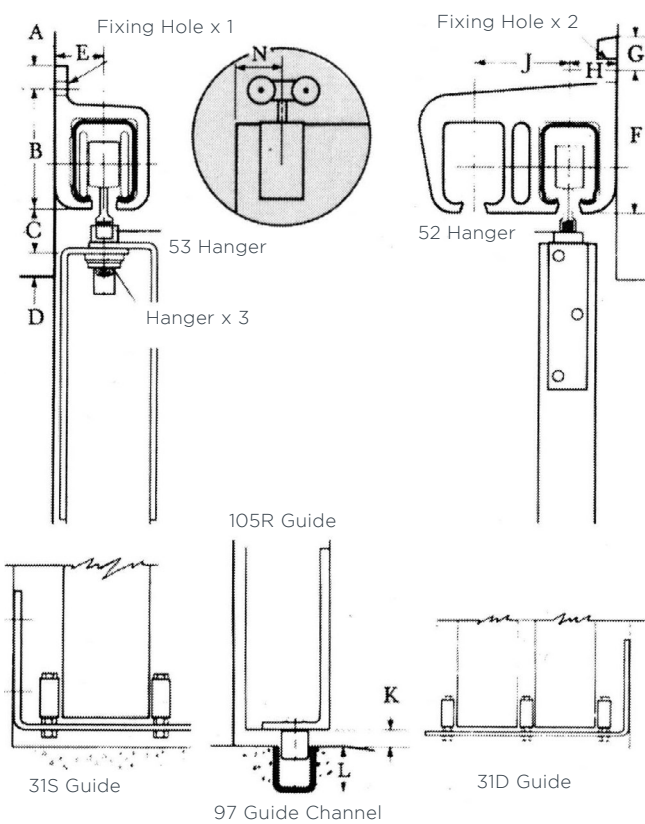

System	A	B	C	D	E	F	G	H	J	K	L
Straight Sliding 290	13	67	25	13	27	80	20	27	54	10	25

System	A	B	C	D	E	F	G	H	J	K	L
Straight Sliding 290	13	67	25	13	27	80	20	27	54	10	25

For further information, please contact us on:

UK Sales

T: +44 (0) 191 377 7345

E: sales@pchenderson.com

W: www.pchenderson.com

Export Sales

T: +44 (0) 191 377 7346

E: international@pchenderson.com

W: export.pchenderson.com